

Year 3: Furious Pharoahs

History

Timeline

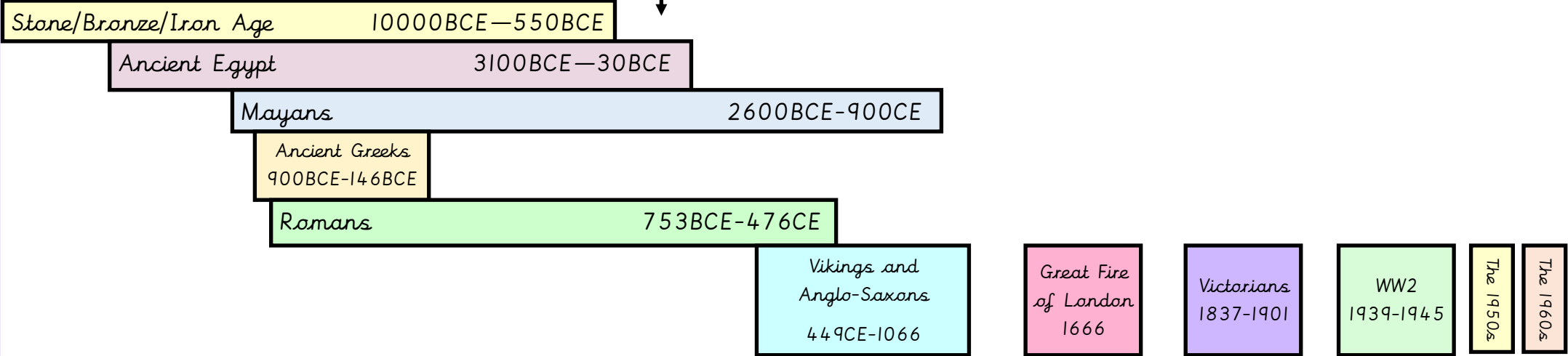

What do we already know?

In Year 3, we already learned:

- We have learnt about timelines in history and the chronology of development in Prehistoric times.
- That we know about history because of discoveries made through archaeology and the importance of the artefacts discovered.

Famous Person



Famous Place



Text Driver













History Skills

Historical Enquiry	We use a variety of sources to look at the discovery of King Tutankhamun's tomb and what information they give us.
Chronology	We look at the chronology of the Ancient Egyptian time and how things change during the period.
Cause and consequence	While investigating mummification, we explore the reasons behind the process and the meaning it holds.

Key Facts

- We explore the social structure in Ancient Egypt and the role of pharaohs.
- We discover how the Ancient Egyptians communicated through hieroglyphics.
- We discuss the uses of the River Nile and debate how important these were to the Ancient Egyptians.
- We explore mummification, the reasons for it and the process used.
- We study the discovery of King Tutankhamun's tomb, and why this is important.

Year 3: Furious Pharoahs

Vocabulary		
Key Word	Image	Definition
Pharaoh		A ruler in Ancient Egypt.
Vizier		A high official in Ancient Egypt.
Archaeologist		A person who studies human and pre-history through exploring artefacts.
Hieroglyphics		The communication system that uses symbols.
Cartouche		A carved tablet with inscriptions.
Papyrus		Paper and materials made from the stems of water plants.
Mummify		The preservation of a body by wrapping it in cloth.
Canopic jar		A covered urn used to store body parts after mummification.
Scribe		The qualified person who recorded information by writing.
Civilisation		The term given to a human culture and time.

Key Questions
When did the Ancient Egyptians live?
How was the social structure organised?
What was a pharaoh and what role did they have?
How did the Ancient Egyptians communicate?
What were pyramids used for?
What did the Ancient Egyptians use the River Nile for and which do you think was most important?
What is mummification and what is involved in the process?

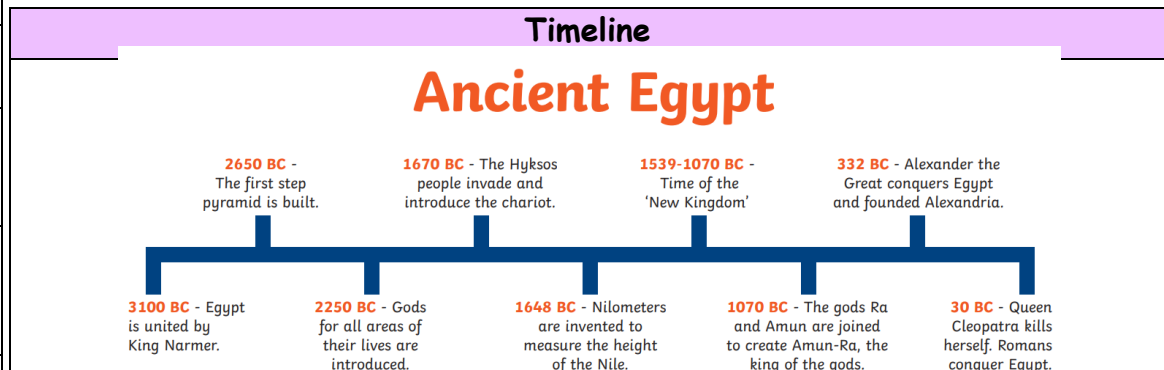

I will know at the end of the project...
1. When the Ancient Egyptians lived and where Egypt is.
2. How the social structure of Ancient Egypt worked, who pharaohs were and how this is similar or different from our society today.
3. What hieroglyphics are and how difficult they are to produce.
4. How many different ways the Ancient Egyptians used the River Nile.
5. Why did the Ancient Egyptians mummify people when they died.